

Principles of Digital Data Transmission

Chapter 7

Lectured by Dr. Yun Q. Shi
Dept. of Electrical & Computer Engr.
New Jersey Institute of Technology

shi@njit.edu

Text used for the course: <Modern Digital and Analog
Communication Systems>, 4th Edition, Lathi and Ding, Oxford

Introduction

- A significant portion of communication in 1990s was in analog.
- It has been replaced rapidly by digital communication.
- Now most of the communications become digital, with analog communication playing a minor role.
- This chapter addresses the framework (several major aspects) of digital data transmission
- All we learnt in this course so far is utilized here.
- Hence, this chapter is naturally a conclusion of this course.

Digital Communication Systems: Source

- Digital Communication Systems: Figure 7.1

Source encoder, Baseband modulation (Line coding), Digital carrier modulation, Multiplexer, Channel, Regenerative repeater, Receiver (detection).

- Source: The input
 - A sequence of digits
 - We discuss mainly: The binary case (two symbols)
 - Later in this chapter: The M-ary case (M symbols)
more general case

Dr. Shi

Lathi & Ding-Digital Commun

3

Figure 7.1 Fundamental building blocks of digital communication systems

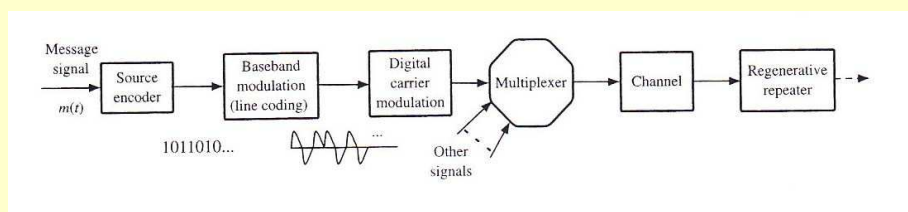

Figure 7.1 Fundamental building blocks of digital communication systems

Dr. Shi

Lathi & Ding-Digital Commun

4

Line Coder (Transmission Coder)

- The output of a multiplexer is coded into electrical pulses or waveforms for the purpose of transmission over the channel.
- This process is called a line coding or transmission coding
- Many possible ways of assigning waveforms (pulses) to the digital data.

- On-off:
$$\begin{cases} 1 & \leftrightarrow & a \text{ pulse } p(t) \\ 0 & \leftrightarrow & no \text{ pulse} \end{cases}$$

Dr. Shi

Lathi & Ding-Digital Commun

5

Line Coder ...

- Polar:
$$\begin{cases} 1 & \leftrightarrow & a \text{ pulse } p(t) \\ 0 & \leftrightarrow & a \text{ pulse } -p(t) \end{cases}$$
- Bipolar (pseudoternary or alternate mark inversion (AMI))
$$\begin{cases} 1 & \leftrightarrow & a \text{ pulse } p(t) \text{ or } -p(t) \text{ depending on whether the previous } 1 \\ & & \text{is encoded by } -p(t) \text{ or } p(t) \\ 0 & \leftrightarrow & no \text{ pulse} \end{cases}$$

In short, pulses representing consecutive 1's alternate in sign.

- All the above three could use half-width pulses. It is possible to select other width.
- Figure 7.1 (parts a, b and c).

Dr. Shi

Lathi & Ding-Digital Commun

6

Line Codes

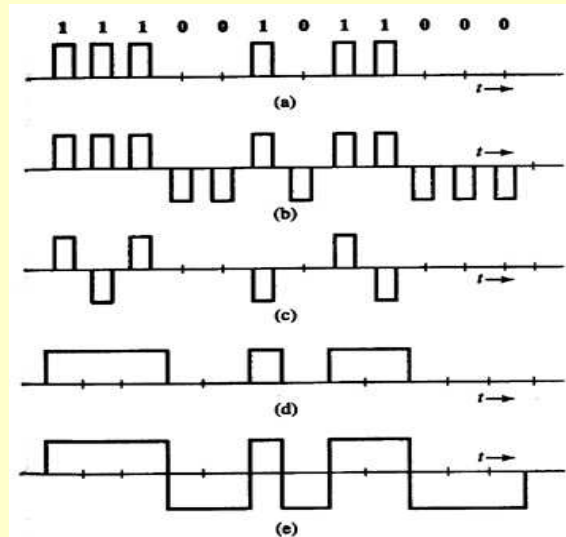

Dr. Shi

Figure 7.2 Some line codes. (a) On-off (RZ). (b) Polar (RZ). (c) Bipolar (RZ). (d) On-off (NRZ). (e) Polar (NRZ).

7

Line Coder ...

- Full width pulses are often used in some applications.
 - i.e., the pulse amplitude is held to a constant value throughout the pulse interval (it does not have a chance to go to zero before the next pulse begins).
 - These schemes are called non return-to-zero (**NRZ**) in contrast to return-to-zero (**RZ**)
 - Figure 7.2 shows
 - An On-off NRZ signal
 - A Polar NRZ signal in d and e parts of the figure

Dr. Shi

Lathi & Ding-Digital Commun

8

Multiplexer

- Usually, the capacity of a practical channel \gg the data rate of individual sources.
- To utilize this capacity effectively, we combine several sources through a digital multiplexer using the process of interleaving.
- One way: A channel is time-shared by several messages simultaneously.

Regenerative Repeater

- Used at regularly spaced intervals along a digital transmission line to: 1) detect the incoming digital signal and 2) regenerate new clean pulses for further transmission along the line.
- This process periodically eliminates, and thereby combats the accumulation of noise and signal distortion along the transmission path.
- The periodic timing information (the clock signal at R_b Hz) is required to sample the incoming signal at a repeater.
- \underline{R}_b (rate): pulses/sec

Regenerative Repeater...

- The clock signal can be extracted from the received signal.
 - e.g., the polar signal
when rectified \Rightarrow a clock signal at R_b Hz
- The on-off signal = A periodic signal at R_b
+ a polar signal (Figure 7.)
- When the periodic signal is applied to a resonant circuit tuned to R_b Hz, the output, a sinusoid of R_b Hz, can be used for timing.

Dr. Shi

Lathi & Ding-Digital Commun

11

On-off Signal Decomposition

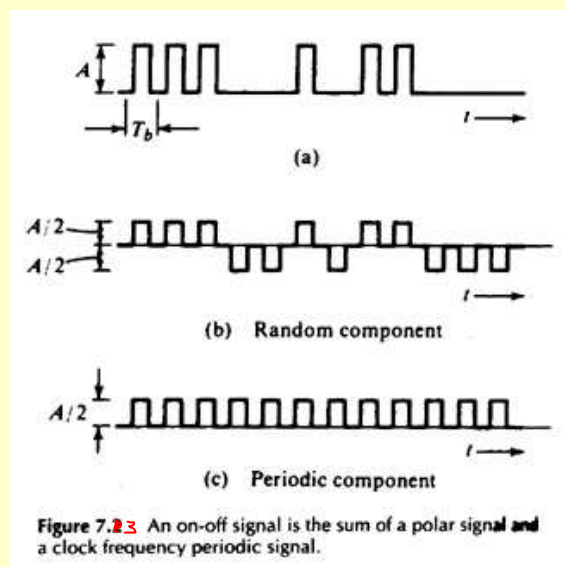

Dr. Shi

Lathi & Ding-Digital Commun

12

Regenerative Repeater...

- The bipolar signal $\xrightarrow{\text{rectified}}$ an on-off signal
 \Rightarrow the clock signal can also be extracted.
- The timing signal (the output of the resonant circuit) is sensitive to the incoming pattern, sometimes.
 - e.g. in on-off, or bipolar } 0 \leftrightarrow no pulse
- If there are too many zeros in a sequence, will have problem.
 - no signal at the input of the resonant circuit for a while
 - sinusoids output of the resonant circuit starts decaying
- Polar scheme has no such a problem.

Transparent Line Code

- A line code in which the bit pattern does not affect the accuracy of the timing information is said to be a transparent line code.
 - The polar scheme is transparent.
 - The on-off and bipolar are not transparent (non-transparent).

Desired Properties of Line Codes

1. Transmission bandwidth: as small as possible
2. Power efficiency: for a specific bandwidth and detection error rate, transmitted power should be as small as possible.
3. Error detection and correction capability: as strong as possible
4. Favorable power spectral density: desirable to have zero PSD at (dc), called DC null, because of ac coupling requires this. If at dc, $\omega = 0$, $PSD \neq 0$, then dc wanders in the pulse stream, which is not desired.
5. Adequate timing content: should be possible to extract the clock signal (timing information).
6. Transparency

PSD of Various Line Codes

- Consider a general PAM signal, as shown in Figure 7.4 (b):

$$R_b \quad T_b = 1/R_b \quad t = kT_b$$

- the k^{th} pulse in the pulse train $y(t) = a_k p(t)$

- $p(t)$: the basic pulse
- $P(\omega)$ [$P(f)$]: Fourier spectrum of $p(t)$
- a_k : arbitrary and random

- The on-off, polar, bipolar line codes are all special cases of the general pulse train $y(t)$, $a_k = 0, +1, -1$ ✓

A Random PAM signal

All 3 line codes can be represented this way

New approach to determine PSD of $y(t)$

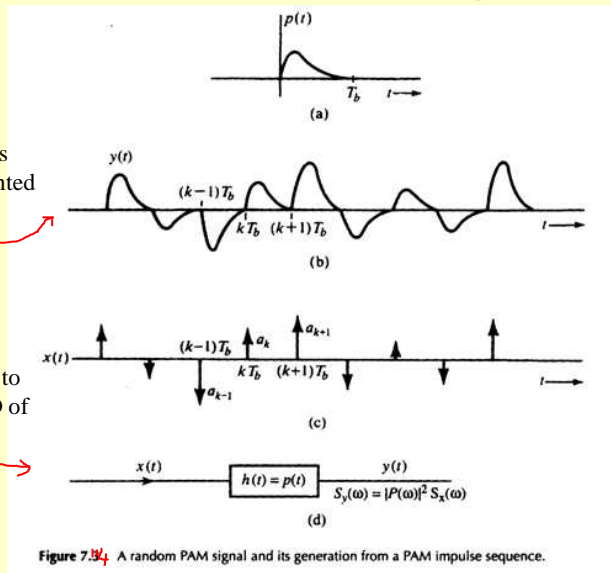

Figure 7.4: A random PAM signal and its generation from a PAM impulse sequence.

Dr. Shi

Lathi & Ding-Digital Commun

17

PSD of Various Line Codes ...

- How to determine the PSD?
 - Figure 7.4
 - An attractive general approach
 - $R_x(\tau), S_x(\omega)$ need to be studied once
 - Then for different $p(t)$, \Rightarrow different PSD
 - $x(t)$: an impulse train
 - $\hat{x}(t)$: a rectangular pulse train ($\varepsilon \cdot h_k = a_k$)
 - when $\varepsilon \rightarrow 0$, $\hat{x}(t) \rightarrow x(t)$
 - (Figure 7.5)

Dr. Shi

Lathi & Ding-Digital Commun

18

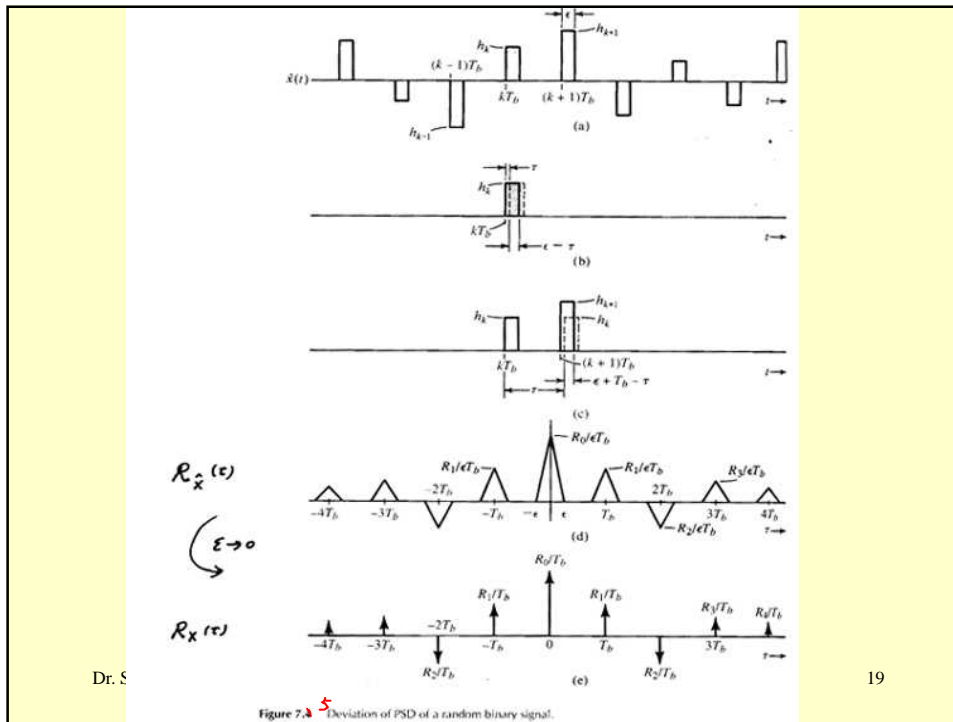

PSD of Various Line Codes ...

$$R_0 = \overline{a_k^2} \Rightarrow \text{time average of } a_k^2$$

$$R_1 = \overline{a_k \cdot a_{k+1}}, \dots, R_n = \overline{a_k \cdot a_{k+n}}$$

$$R_X(\tau) = \frac{1}{T_b} \sum_{n=-\infty}^{\infty} R_n \delta(\tau - nT_b)$$

$$S_X(\omega) = \frac{1}{T_b} \sum_{n=-\infty}^{\infty} R_n e^{-jn\omega T_b} = \frac{1}{T_b} \left[R_0 + 2 \sum_{n=1}^{\infty} [R_n \cos(n\omega T_b)] \right]$$

$$S_y(\omega) = |P(\omega)|^2 S_X(\omega)$$

Different line codes \Rightarrow different $P(\omega) \Rightarrow$ different $S_y(\omega)$

Polar Signaling

$$\left. \begin{array}{l} 1 \leftrightarrow p(t) \\ 0 \leftrightarrow -p(t) \end{array} \right\} \cdot a_k = \pm 1, \text{equally likely}, a_k^2 = 1$$

$$R_0 = \overline{a_k^2} = 1$$

$$R_1 = \overline{a_k \cdot a_{k+1}} = 0 \quad \because a_k \cdot a_{k+1} = 1 \text{ or } -1$$

equally likely

$$R_n = 0, n \geq 1 \quad \text{Similar reasoning}$$

$$\begin{aligned} S_y(\omega) &= |P(\omega)|^2 \cdot S_x(\omega) \\ &= |P(\omega)|^2 \cdot \frac{1}{T_b} \end{aligned}$$

Dr. Shi

Lathi & Ding-Digital Commun

21

Polar Signaling...

- To be specific, assume $p(t)$ is a rectangular pulse of width $\frac{T_b}{2}$ (a half-width rectangular pulse)

$$p(t) = \text{rect} \left(\frac{t}{\frac{T_b}{2}} \right)$$

$$P(\omega) = \frac{T_b}{2} \text{sinc} \left(\frac{\omega T_b}{4} \right)$$

$$S_y(\omega) = \frac{T_b}{4} \text{sinc}^2 \left(\frac{\omega T_b}{4} \right)$$

1st zero-crossing:

$$\frac{\omega T_b}{4} = \pi \Rightarrow \omega = \frac{4\pi}{T_b}$$

$$\text{or } \Rightarrow f = \frac{2}{T_b} = 2R_b$$

Dr. Shi

Lathi & Ding-Digital Commun

22

PSD of polar signal (half-width rectangle)

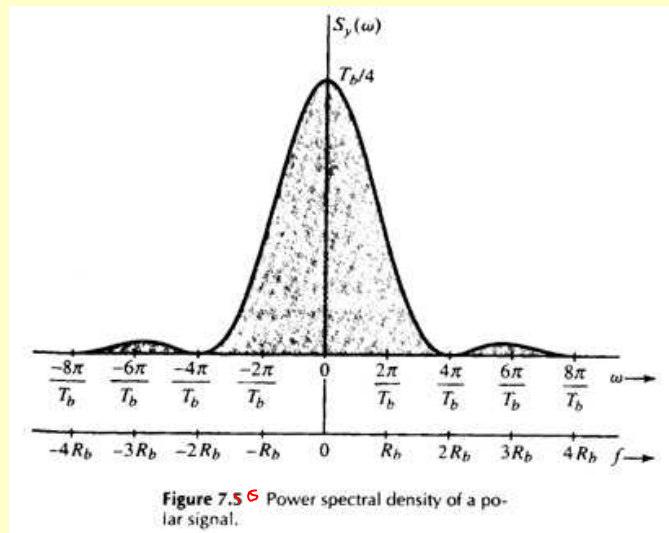

Dr. Shi

Lathi & Ding-Digital Commun

23

Polar Signaling ...

- Comment 1: The essential bandwidth of the signal (main lobe) = $2 R_b$
For a full-width pulse, $\Rightarrow R_b$
“Polar Signaling is not bandwidth efficient.”
- Comment 2: “No error-detection or error-correction capability.”
- Comment 3: “Non-zero PSD at dc ($\omega = 0$)”
 \Rightarrow This will rule out the use of ac coupling in transmission.
- Comment 4: “Most efficient scheme from the power requirement viewpoint” \rightarrow for a given power, the detection-error probability for a polar scheme is the smallest possible.
- Comment 5: “Transparent”

Dr. Shi

Lathi & Ding-Digital Commun

24

Achieving DC Null in PSD by Pulse Shaping

$$\because P(\omega) = \int_{-\infty}^{\infty} p(t)e^{-j\omega t} dt$$

$$\therefore P(0) = \int_{-\infty}^{\infty} p(t)dt$$

\Rightarrow If the area under $p(t) = 0$, $P(0) = 0$.

Manchester (split-phase, twinned-binary) Signal

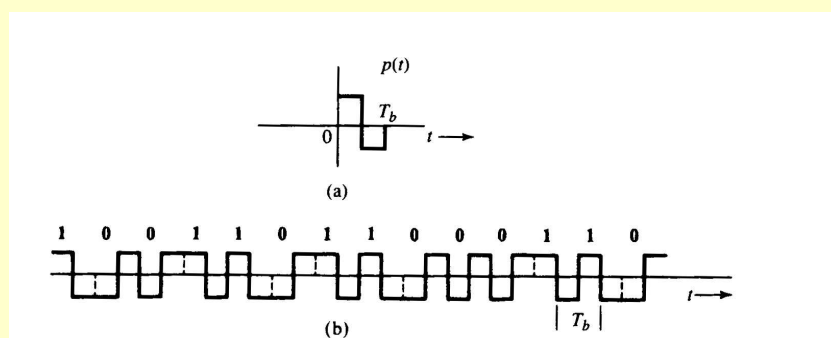

Figure 7.6 7 Split-phase (Manchester or twinned-binary) signal. (a) Basic pulse $p(t)$ for Manchester signaling. (b) Output of Manchester signaling.

On-off Signaling

• 1 \leftrightarrow p(t)

0 \leftrightarrow no pulse

$$R_0 = \frac{1}{2}$$

$$R_n = \frac{1}{4} \quad \text{for all } n \geq 1$$

$$\begin{aligned} S_X(\omega) &= \frac{1}{2T_b} + \frac{1}{4T_b} \sum_{\substack{n=-\infty \\ n \neq 0}}^{\infty} e^{-jn\omega T_b} \\ &= \frac{1}{4T_b} + \frac{1}{4T_b} \sum_{n=-\infty}^{\infty} e^{-jn\omega T_b} \end{aligned}$$

Dr. Shi

Lathi & Ding-Digital Commun

27

On-off Signaling

$$S_X(\omega) = \frac{1}{4T_b} + \frac{2\pi}{4T_b^2} \sum_{n=-\infty}^{\infty} \delta\left(\omega - \frac{2\pi n}{T_b}\right)$$

$$S_y(\omega) = \frac{|P(\omega)|^2}{4T_b} \left[1 + \frac{2\pi}{T_b} \sum_{n=-\infty}^{\infty} \delta\left(\omega - \frac{2\pi n}{T_b}\right) \right]$$

For a half-width rectangular pulse,

$$S_y(\omega) = \frac{T_b}{16} \text{sinc}^2\left(\frac{\omega T_b}{4}\right) \left[1 + \frac{2\pi}{T_b} \sum_{n=-\infty}^{\infty} \delta\left(\omega - \frac{2\pi n}{T_b}\right) \right]$$

Note: 1. For some derivation, refer to the next four pages.

2. PSD is shown in Figure 7.8.

3. PSD consists of both a discrete part and a continuous part.

Dr. Shi

Lathi & Ding-Digital Commun

28

Some Derivation

(Lathi's book, pp. 58-59, Example 2.12)

- A unit impulse train: $\delta_{T_0}(t) = \text{Comb}_{T_0}(t) = g(t)$

$$\begin{aligned} \underline{g(t)} &= \sum_{n=-\infty}^{\infty} D_n e^{jn\omega_b t} = \frac{1}{T_b} \sum_{n=-\infty}^{\infty} e^{jn\omega_b t} \\ &= \frac{1}{T_b} + \frac{2}{T_b} \sum_{n=1}^{\infty} \cos(n\omega_b t) \end{aligned}$$

$$G(f) = FT\{g(t)\} = \frac{1}{T_0} \sum_{n=-\infty}^{\infty} \delta(f - nf_0)$$

$$\begin{aligned} G(\omega) = FT\{g(t)\} &= \frac{2\pi}{T_0} \sum_{n=-\infty}^{\infty} \delta(\omega - n\frac{2\pi}{T_0}) \\ &\cong \omega_0 \text{COMB}_{\omega_0}(\omega) \end{aligned}$$

Dr. Shi

Lathi & Ding-Digital Commun

29

Example 2.12

EXAMPLE 2.12 Find the exponential Fourier series and sketch the corresponding spectra for the impulse train $\delta_{T_0}(t)$ shown in Fig. 2.27.

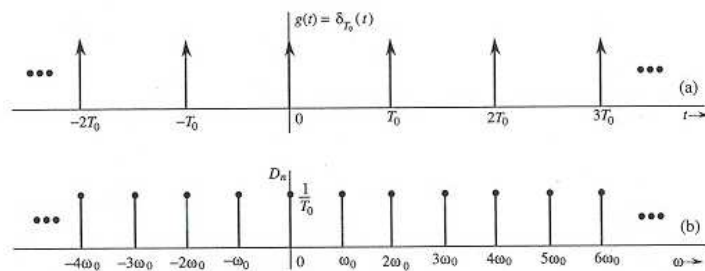

Figure 2.27 Impulse train and its exponential Fourier spectra.

Dr. Shi

Lathi & Ding-Digital Commun

30

Some Derivation...

- Fact 1 (Lathi's book, p.83, Eq. (3.20a, 3.20b):

$$1 \leftrightarrow \delta(f)$$

$$e^{j2\pi f_b t} \leftrightarrow \delta(f - f_b) \quad \left[e^{j\omega_b t} \leftrightarrow \delta(\omega - \omega_b) \right]$$

- Fact 2: Also,

$$\delta(t) \leftrightarrow 1$$

$$\delta(t - nT_b) \leftrightarrow e^{-jn\omega_b T_b}$$

Dr. Shi

Lathi & Ding-Digital Commun

31

Some Derivation ...

- Fact 3:

$$\underbrace{\sum_{n=-\infty}^{\infty} \delta(t - nT_b)}_{\updownarrow FT} \stackrel{FS}{=} \underbrace{\frac{1}{T_b} \sum_{n=-\infty}^{\infty} e^{jn\omega_b t}}_{\updownarrow FT} \quad \omega_b = \frac{2\pi}{T_b}$$

$$\underbrace{\sum_{n=-\infty}^{\infty} e^{-jn\omega_b t}}_{\updownarrow FT} = \omega_b \sum_{n=-\infty}^{\infty} \delta(\omega - n\omega_b)$$

Dr. Shi

Lathi & Ding-Digital Commun

32

PSD of An On-off Signal

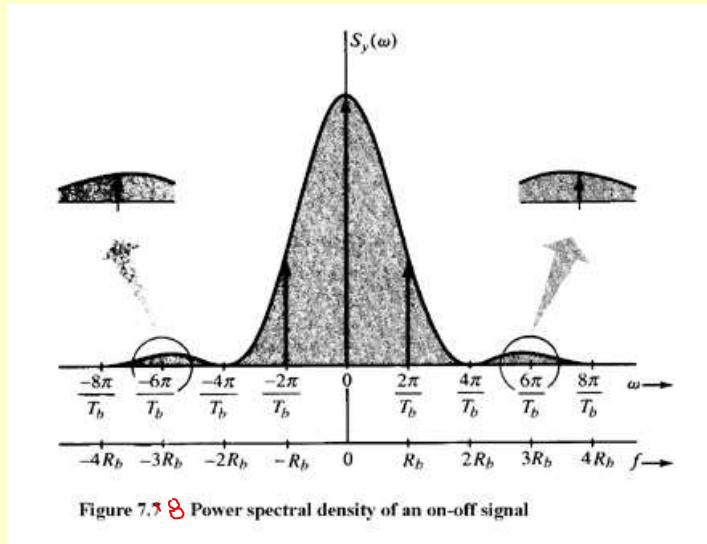

Dr. Shi

Lathi & Ding-Digital Commun

33

On-off Signaling

- This is reasonable since, as shown in Fig. 7.2, an on-off signal can be expressed as the sum of a polar and a periodic component
- Comment 1: For a given transmitted power, it is less immune to noise interference.
 - \therefore Noise immunity \propto difference of amplitudes representing binary 0 and 1.
 - If a pulse of amplitude 1 or -1 has energy E , then a pulse of amplitude 2 has energy $(2)^2E = 4E$.

Dr. Shi

Lathi & Ding-Digital Commun

34

On-off Signaling ...

- For polar: $\frac{1}{T_b}$ digits are transmitted per second
 \therefore polar signal power $= E \left(\frac{1}{T_b} \right) = \frac{E}{T_b}$
- For on-off: $power = 4E \left(\frac{1}{2T_b} \right) = \frac{2E}{T_b}$ Power is now as large as twice of above.
- Comment 2: Not transparent

Bipolar Signaling

(Pseudoternary or Alternate Mark Inverted (AMI))

- A. $0 \leftrightarrow$ no pulse
 $1 \leftrightarrow p(t)$ or $-p(t)$ depending on whether the previous 1 was transmitted by $-p(t)$ or $p(t)$
- B. $[p(t), 0, -p(t)]$: In reality, it is ternary signaling.
- C. Merit: a dc null in PSD
demerit: not transparent

Bipolar Signaling...

$$D. R(0) = \lim_{N \rightarrow \infty} \frac{1}{N} \sum_k a_k^2 = \lim_{N \rightarrow \infty} \frac{1}{N} \left[\frac{N}{2} (\pm 1)^2 + \frac{N}{2} (0) \right] = \frac{1}{2}$$

$$R(1) = \lim_{N \rightarrow \infty} \frac{1}{N} \left[\frac{N}{4} (-1) + \frac{3N}{4} (0) \right] = -\frac{1}{4}$$

$$R(2) \quad a_k a_{k+n} \quad 111, 101, 110, 011, 010, 001, 000$$

$$R(2) = \lim_{N \rightarrow \infty} \frac{1}{N} \left[\frac{N}{8} (1) + \frac{N}{8} (-1) + \frac{5N}{8} (0) \right] = 0$$

$$R_n = \lim_{N \rightarrow \infty} \frac{1}{N} \sum_k a_k a_{k+n} = 0, n > 1$$

Dr. Shi

Lathi & Ding-Digital Commun

37

Bipolar Signaling...

$$E. S_y(\omega) = |P(\omega)|^2 S_x(\omega) = \frac{|P(\omega)|^2}{T_b} \left(\sum_{n=-\infty}^{\infty} R_n e^{-jn\omega T_b} \right) \quad (7.10b)$$

$$= \frac{|P(\omega)|^2}{T_b} \left(R_0 + 2 \sum_{n=1}^{\infty} R_n \cos n\omega T_b \right) \quad (7.10c)$$

$$= \frac{|P(\omega)|^2}{T_b} \left(\frac{1}{2} + 2 \cdot \left(-\frac{1}{4}\right) \cos \omega T_b \right)$$

$$= \frac{|P(\omega)|^2}{2 \cdot T_b} (1 - \cos \omega T_b) = \frac{|P(\omega)|^2}{T_b} \sin^2 \left(\frac{\omega T_b}{2} \right)$$

Dr. Shi

Lathi & Ding-Digital Commun

38

Bipolar Sampling ...

$\Rightarrow S_y(\omega) = 0$ As $\omega=0$ (dc) regardless of $P(\omega)$
A dc null (desirable for ac coupling)

$$\sin^2\left(\frac{\omega T_b}{2}\right) = 0 \quad \text{at} \quad \omega = \frac{2\pi}{T_b}, \therefore f = \frac{1}{T_b} = R_b$$

\Rightarrow bandwidth = R_b Hz, regardless of $P(\omega)$

For a half-width rectangular pulse, $\frac{T_b}{2}$, $P_x(t) = \text{rect}\left(\frac{t}{\frac{T_b}{2}}\right)$

$$P(\omega) = \frac{T_b}{2} \text{sinc}\left(\frac{\omega}{\frac{4}{T_b}}\right)$$

$$\Rightarrow S_y(\omega) = \frac{T_b}{4} \text{sinc}^2\left(\frac{\omega T_b}{4}\right) \sin^2\left(\frac{\omega T_b}{2}\right)$$

$$\omega_1 T_b = 4\pi \quad \omega_2 T_b = 2\pi$$

$$\text{Zero:} \quad \omega_1 = \frac{4\pi}{T_b} \quad \omega_2 = \frac{2\pi}{T_b} \quad \Rightarrow R_b = \left(\frac{1}{T_b}\right)$$

$$f_1 = 2R_b \quad f_2 = R_b \quad \text{essential bandwidth}$$

Half that of polar or on-off signaling.

Twice that of theoretical minimum bandwidth (channel b/w).

Table 3.1:

$$\text{rect}\left[\frac{t}{\tau}\right] \leftrightarrow \tau \text{sinc}\left(\frac{\omega \tau}{2}\right) = \tau \text{sinc}\left(\frac{\omega}{\frac{2}{\tau}}\right)$$

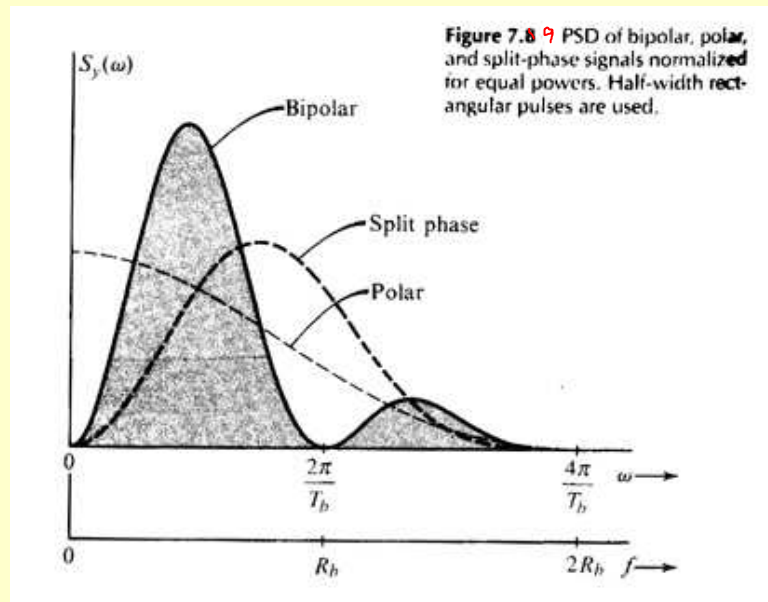

Dr. Shi

Lathi & Ding-Digital Commun

41

Merits of Bipolar Signaling

1. Spectrum has a dc null.
2. Bandwidth is not excessive.
3. It has single-error-detection capability.

Since, a single detection error \Rightarrow a violation of the alternation pulse rule.

Dr. Shi

Lathi & Ding-Digital Commun

42

Demerits of Bipolar Signaling

1. Requires twice as much power as a polar signaling.

Distinction between A , $-A$, 0

vs.

Distinction between $A/2$, $-A/2$

2. Not transparent

Pulse Shaping

$$S_y(\omega) = |P(\omega)|^2 S_X(\omega)$$
$$= \frac{|P(\omega)|^2}{T_b} (R_0 + 2 \sum_{n=1}^{\infty} R_n \cos n\omega T_b) \quad [\text{Slide 19}]$$

- Different signaling (line coding, $S_X(\omega)$) \Rightarrow diff. $S_y(\omega)$
- Different pulse shaping ($P(\omega)$) \Rightarrow diff. $S_y(\omega)$
An additional factor.
- Intersymbol Interference (ISI) (refer to the next slide)
 - Time-limited pulses (i.e., truncation in time domain) \rightarrow not band-limited in frequency domain
 - Not time-limited, causes problem \leftarrow band-limited signal (i.e., truncation in frequency domain)

Intersymbol Interference (ISI) in Detection

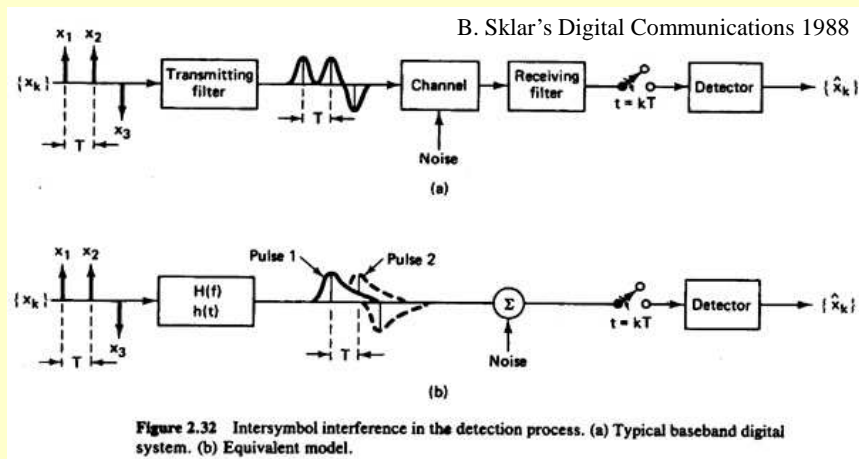

Dr. Shi

Lathi & Ding-Digital Commun

Back to slide 44

45

Phase Shaping... Intersymbol Interference (ISI)

- Whether we begin with time-limited pulses or band-limited pulses, it appears that ISI cannot be avoided.
An inherent problem in the finite bandwidth transmission.
- Fortunately, there is a way to get away:
be able to detect pulse amplitudes correctly.

Dr. Shi

Lathi & Ding-Digital Commun

46

Nyquist Criterion for Zero ISI

- The first method proposed by Nyquist.

$$p(t) = \begin{cases} 1, & t = 0 \\ 0, & t = \pm nT_b \end{cases} \quad T_b = \frac{1}{R_b} \quad (7.22)$$

T_b : separation between successive transmitted pulses

- Example 6.1 (p.256)

$$p(t) = \text{sinc}(2\pi Bt), \quad B = \frac{1}{2T_b} = \frac{1}{2} R_b$$

Since $2\pi B T_b = \pi$, T_b is the 1st zero crossing.

- Minimum bandwidth pulse that satisfies Nyquist Criterion Fig. 7.10 (b and c)

Dr. Shi

Lathi & Ding-Digital Commun

47

Minimum Bandwidth Pulse (Nyquist Criterion)

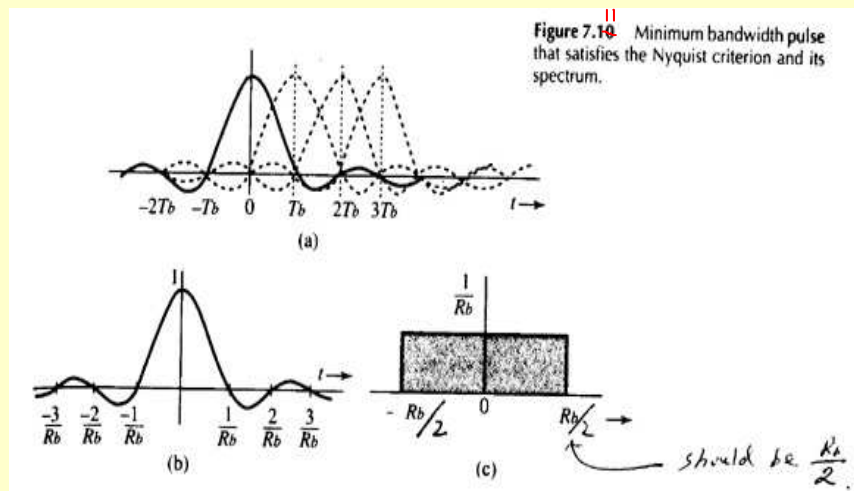

Dr. Shi

Lathi & Ding-Digital Commun

48

Nyquist Criterion for Zero ISI...

$$p(t) = \text{sinc}(\pi R_b t) = \begin{cases} 1 & t = 0 \\ 0 & t = \pm nT_b \end{cases} \quad \left(T_b = \frac{1}{R_b} \right)$$

$$P(\omega) = \frac{1}{R_b} \text{rect} \left(\frac{\omega}{2\pi R_b} \right) \quad \text{bandwidth} = \frac{R_b}{2}$$

Table 3.1:

$$\frac{W}{\pi} \text{Sinc}(Wt) \overset{\text{FT}}{\leftrightarrow} \text{rect} \left(\frac{\omega}{2W} \right)$$

Problems of This Method

- Impractical
 1. $-\infty < t < \infty$
 2. It decays too slowly at a rate $1/t$. \Rightarrow Any small timing problem (deviation) \Rightarrow ISI
- Solution: Find a pulse satisfying Nyquist criterion (7.22), but decays faster than $1/t$.
- Nyquist: Such a pulse requires a bandwidth

$$k \cdot \frac{R_b}{2}, \quad 1 \leq k \leq 2$$

- Let $p(t) \leftrightarrow P(\omega)$
 - The bandwidth of $P(\omega)$ is in $(R_b/2, R_b)$
 - $p(t)$ satisfies Nyquist criterion Equation (7.22)
- Sampling $p(t)$ every T_b seconds by multiplying $p(t)$ by an impulse train $\delta_{T_b}(t)$.

$$\Rightarrow \bar{p}(t) = p(t) \delta_{T_b}(t) = \delta(t)$$

\Updownarrow FT

$$\Rightarrow \frac{1}{T_b} \sum_{n=-\infty}^{\infty} P(\omega - n\omega_b) = 1$$

Equation (6.4)

$$\overline{G(\omega)} = \frac{1}{T_s} \sum_{n=-\infty}^{\infty} P(\omega - n\omega_s)$$

Dr. Shi

Lathi & Ding-Digital Commun

51

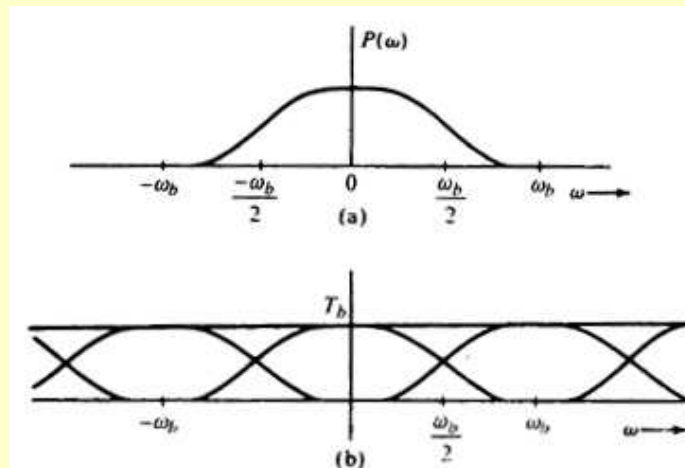

12
Figure 7.14 Derivation of the Nyquist criterion pulse.

Dr. Shi

Lathi & Ding-Digital Commun

52

Derivation

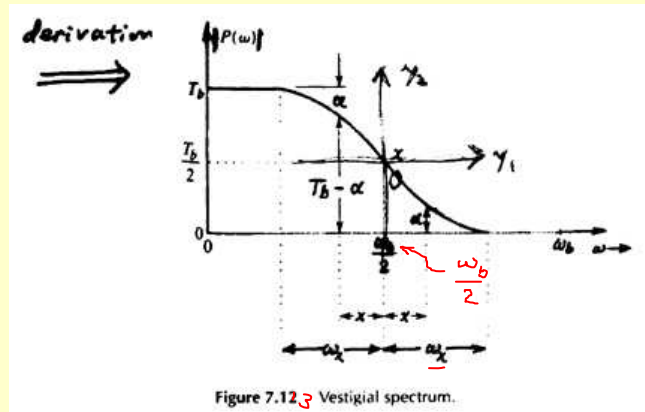

- $|P(\omega)|$ is odd symmetric in y_1 -o- y_2 system.

Dr. Shi

Lathi & Ding-Digital Commun

53

Derivation...

- The bandwidth of $P(\omega)$ is $\frac{\omega_b}{2} + \omega_x$
- ω_x : the excess bandwidth

$$\begin{aligned}
 \text{roll-off factor } \gamma &= \frac{\text{excess bandwidth}}{\text{theoretical minimum bandwidth}} \\
 &= \frac{\omega_x}{\frac{\omega_b}{2}} = 2 \cdot \frac{\omega_x}{\omega_b} \quad 0 \leq r \leq 1
 \end{aligned}$$

- The bandwidth of $P(\omega)$ is $B_r = \frac{R_b}{2} + \frac{rR_b}{2} = (1 + \gamma) \frac{R_b}{2}$
- $P(\omega)$, thus derived, is called a **Vestigial Spectrum**.

Dr. Shi

Lathi & Ding-Digital Commun

54

Realizability

- A physically realizable system, $h(t)$, must be causal, i.e., $h(t) = 0$, for $t < 0$. (The n.c. & s.c.)
- In the frequency domain, the n.c. & s.c. is known as Paley-Wiener criterion

$$\int_{-\infty}^{\infty} \frac{|\ln |H(\omega)| |}{1 + \omega^2} d\omega < \infty$$

- Note that, for a physically realizable system, $H(\omega)$ may be zero at some discrete frequencies.
But, it cannot be zero over any finite band
- So, ideal filters are clearly unrealizable.

- From this point of view, the vestigial spectrum $P(\omega)$ is unrealizable.
- However, since the vestigial roll-off characteristic is gradual, it can be more closely **approximated** by a practical filter.
- One family of spectra that satisfies the Nyquist criterion is

$$P(\omega) = \begin{cases} 1/2 \left\{ 1 - \sin \left(\frac{\pi(\omega - \frac{\omega_b}{2})}{2\omega_x} \right) \right\} & \left| \omega - \frac{\omega_b}{2} \right| < \omega_x \\ 0 & \left| \omega \right| > \frac{\omega_b}{2} + \omega_x \\ 1 & \left| \omega \right| < \frac{\omega_b}{2} - \omega_x \end{cases}$$

Realizability ...

$$\left. \begin{array}{l} \omega_x = 0 \quad (r = 0) \\ \omega_x = \frac{\omega_b}{4} \quad (r = 0.5) \\ \omega_x = \frac{\omega_b}{2} \quad (r = 1) \end{array} \right\} \text{ Shown in the figure on next slide}$$

- **Comment 1:** Increasing ω_x (or r) improves $p(t)$, i.e., more gradual cutoff reduces the oscillatory nature of $p(t)$, $p(t)$ decays more rapidly.

Pulses satisfying Nyquist Criterion

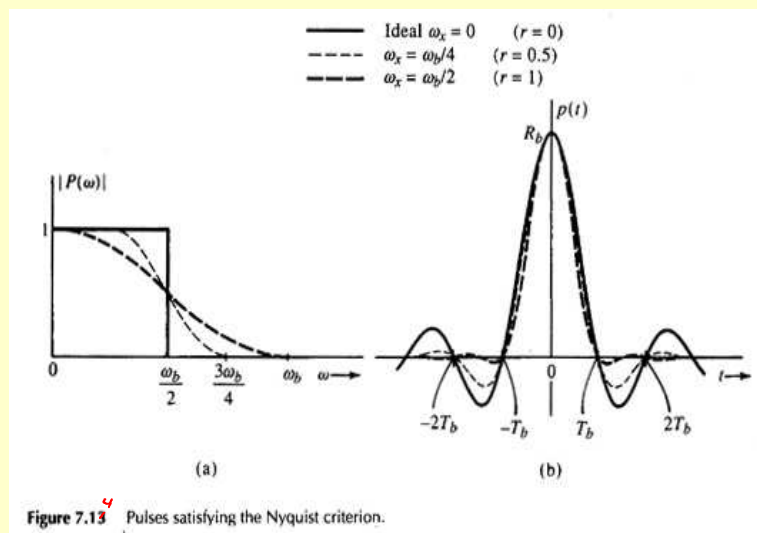

Figure 7.13 Pulses satisfying the Nyquist criterion.

Realizability...

- Comment 2: As $\gamma = 1$, i.e., $\omega_x = \frac{\omega_b}{2}$

$$\begin{aligned} P(\omega) &= \frac{1}{2} \left(1 + \cos \frac{\omega}{2R_b} \right) \text{rect} \left(\frac{\omega}{4\pi R_b} \right) \\ &= \cos^2 \left(\frac{\omega}{4R_b} \right) \text{rect} \left(\frac{\omega}{4\pi R_b} \right) \end{aligned}$$

- This characteristic is known as:

The raised-cosine characteristic

The full-cosine roll-off characteristic

Realizability...

$$p(t) = R_b \frac{\cos(\pi R_b t)}{1 - 4R_b^2 t^2} \text{Sinc}(\pi R_b t)$$

- A. Bandwidth is R_b ($\gamma=1$)
- B. $p(0) = R_b$
- C. $p(t) = 0$ at all the signaling instants
&
at points midway between all the signaling instants
- D. $p(t)$ decays rapidly as $1/t^3 \Rightarrow$ relatively insensitive to derivations of R_b , sampling rate, timing jitter and so on.

Realizability...

- E. Closely realizable
- F. Can also be used as a duobinary pulse.
- G. $H_c(\omega)$: channel transfer factor

$P_i(k)$: transmitted pulse

$$P_i(\omega) \cdot H_c(\omega) = P(\omega)$$

Received pulse at the detector input should be $P(\omega)$ [$p(t)$].

Signaling with Controlled ISI: Partial Response Signals

- The second method proposed by Nyquist to overcome ISI.
- Duobinary pulse: $p(nT_b) = \begin{cases} 1 & n = 0, 1 \\ 0 & \text{for all other } n \end{cases}$

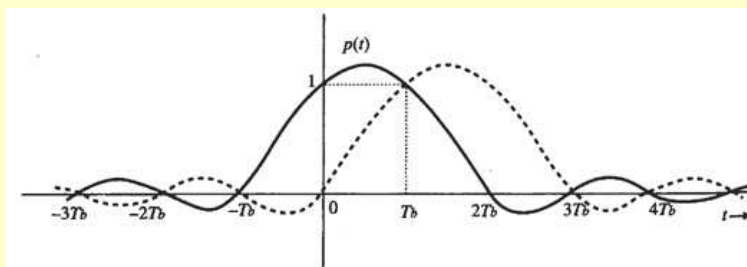

Figure 7.145 Communication using duobinary pulses.

Signaling with Controlled ISI...

- Use polar signaling
$$1 \leftrightarrow p(t)$$
$$0 \leftrightarrow -p(t)$$
- The received signal is sampled at $t = nT_b$
$$p(t) = 0 \quad \text{for all } n \text{ except } n = 0, 1.$$
- Clearly, such a pulse causes zero ISI with all the pulses except the succeeding pulses.

Dr. Shi

Lathi & Ding-Digital Commun

63

Signaling with Controlled ISI...

- Consider two such successive pulses located at 0 and T_b .
 - If both pulses are positive, the sample value at $t = T_b$
$$\Rightarrow 2.$$
 - If both pulses are negative, $\Rightarrow -2$
 - If pulses are of opposite polarity, $\Rightarrow 0$
- **Decision Rule:** If the sample value at $t = T_b$ is
 - Positive $\Rightarrow 1, 1$
 - Negative $\Rightarrow 0, 0$
 - Zero $\Rightarrow 0, 1$ or $1, 0$

Dr. Shi

Lathi & Ding-Digital Commun

64

Signaling with Controlled ISI...

- Table 7.1

Transmitted Seq.	1	1	0	1	1	0	0	0	1	0	1	1	1
Sample of $x(T_b)$	1	2	0	0	2	0	-2	-2	0	0	0	2	2
Detected seq.	1	1	0	1	1	0	0	0	1	0	1	1	1

Signaling with Controlled ISI: Duobinary Pulses

- If the pulse bandwidth is restricted to be $\frac{R_b}{2}$ it can be shown that the $p(t)$ must be:

$$p(t) = \frac{\sin(\pi R_b t)}{\pi R_b t(1 - R_b t)}$$

$$P(\omega) = \frac{2}{R_b} \cos\left(\frac{\omega}{2R_b}\right) \text{rect}\left(\frac{\omega}{2\pi R_b}\right) e^{-j\frac{\omega}{2R_b}}$$

- Note: The raised-cosine pulse with $\omega_x = \frac{\omega_b}{2}, (r=1)$, satisfies the condition (7.3b) to be signaling with controlled ISI – refer to Figure 7.13 (slides 57).

Signaling with Controlled ISI Duobinary Pulses...

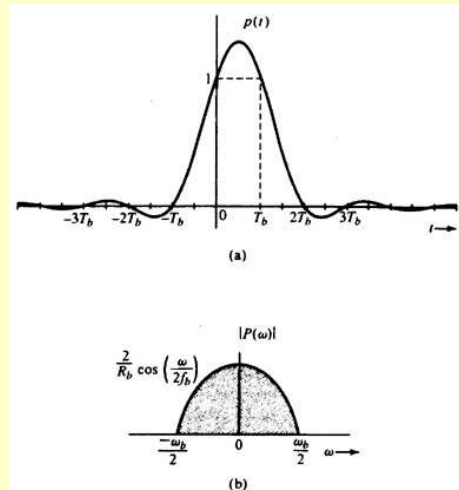

Figure 7.16 Minimum-bandwidth pulse that satisfies the duobinary pulse criterion and its spectrum.

Dr. Shi

67

Use of Differential Coding

- For the controlled ISI method,
0-valued sample \Rightarrow 0 to 1 or 1 to 0 transition.
- An error may be propagated.
- Differential coding helps.
- In differential coding, “1” is transmitted by a pulse identical to that used for the previous bit. “0” is transmitted by a pulse negative to that used for the previous bit.
- Useful in systems that have no sense of absolute polarity. \rightarrow Fig 7.17

Dr. Shi

Lathi & Ding-Digital Commun

68

Differential Code

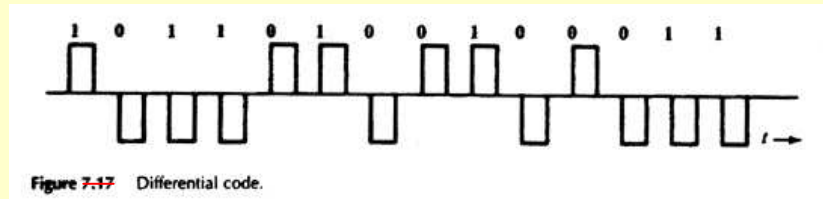

Scrambling

- Purpose: A scrambler tends to make the data more random by
 - Removing long strings of 1's or 0's
 - Removing periodic data strings.
 - Used for preventing unauthorized access to the data.

- Example. (Structure)

Scrambler: $S \oplus D^3T \oplus D^5T = T$ → Incomplete version

D^nT : T delayed by n units

\oplus : Modulo 2 Sum

$$1 \oplus 1 = 0 \quad 1 \oplus 0 = 1$$

$$0 \oplus 0 = 0 \quad 0 \oplus 1 = 1$$

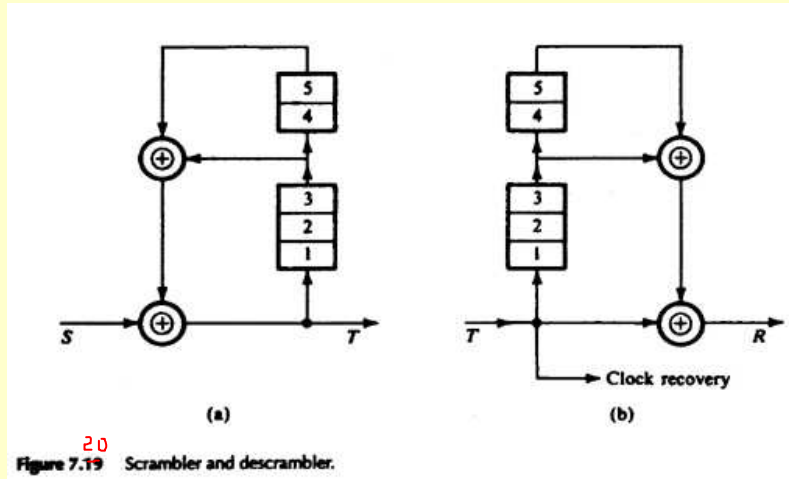

Scrambling...

- Descrambler:

Incomplete version

$$\begin{aligned}
 R &= T \oplus (D^3 \oplus D^5)T \\
 &= [1 \oplus (D^3 \oplus D^5)]T \\
 &= (1 \oplus F)T \\
 F &\stackrel{\Delta}{=} D^3 \oplus D^5
 \end{aligned}$$

Example 7.2

- The data stream 101010100000111 is fed to the scrambler in Fig. 7.19a. Find the scrambler output T, assuming the initial content of the registers to be zero.
 - From Fig. 7.19a we observe that initially $T = S$, and the sequence S enters the register and is returned as $(D^3 \oplus D^5)S = FS$ through the feedback path. This new sequence FS again enters the register and is returned as F^2S , and so on. Hence,

$$\begin{aligned}
 & T = S \oplus FS \oplus F^2S \oplus F^3S \oplus \dots \quad (7.41) \\
 \text{Complete version } & = (1 \oplus F \oplus F^2 \oplus F^3 \oplus \dots) S
 \end{aligned}$$

Example 7.2 ...

- Recognizing that $F = D^3 \oplus D^5$
We have

$$F^2 = (D^3 \oplus D^5)(D^3 \oplus D^5) = D^6 \oplus D^{10} \oplus D^8 \oplus D^8$$
- Because modulo-2 addition of any sequence with itself is zero, $D^8 \oplus D^8 = 0$ and

$$F^2 = D^6 \oplus D^{10}$$

- Similarly,

$$F^3 = (D^6 \oplus D^{10})(D^3 \oplus D^5) = D^9 \oplus D^{11} \oplus D^{13} \oplus D^{15}$$

Example 7.2 ...

..... and so on

Hence,

$$T = (1 \oplus D^3 \oplus D^5 \oplus D^6 \oplus D^9 \oplus D^{10} \oplus D^{11} \oplus D^{12} \oplus D^{13} \oplus D^{15} \oplus \dots)S$$

Because $D^n S$ is simply the sequence S delayed by n bits, various terms in the preceding equation correspond to the following sequences:

Example 7.2 ...

$$S = 101010100000111$$

$$D^3 S = 000101010100000111$$

$$D^5 S = 00000101010100000111$$

$$D^6 S = 000000101010100000111$$

$$D^9 S = 000000000101010100000111$$

$$D^{10} S = 0000000000101010100000111$$

$$D^{11} S = 00000000000101010100000111$$

$$D^{12} S = 000000000000101010100000111$$

$$D^{13} S = 0000000000000101010100000111$$

$$D^{15} S = 000000000000000101010100000111$$

$$T = 101110001101001$$

Example 7.2 ...

- Note that the input sequence contains the periodic sequence 10101010..., as well as a long string of 0's.
- The scrambler output effectively removes the periodic component as well as the long strings of 0's.
- The input sequence has 15 digits. The scrambler output up to the 15th digit only is shown, because all the output digits beyond 15 depend on the input digits beyond 15, which are not given.
- We can verify that the descrambler output is indeed S when this sequence T is applied at its input.
- Homework: Learn to be able to determine where no terms needs to be considered.

Regenerative Repeater

- Three functions:
 1. Reshaping incoming pulses using an equalizer.
 2. Extracting timing information
Required to sample incoming pulses at optimum instants.
 3. Making decision based on the pulse samples

Regenerative Repeater...

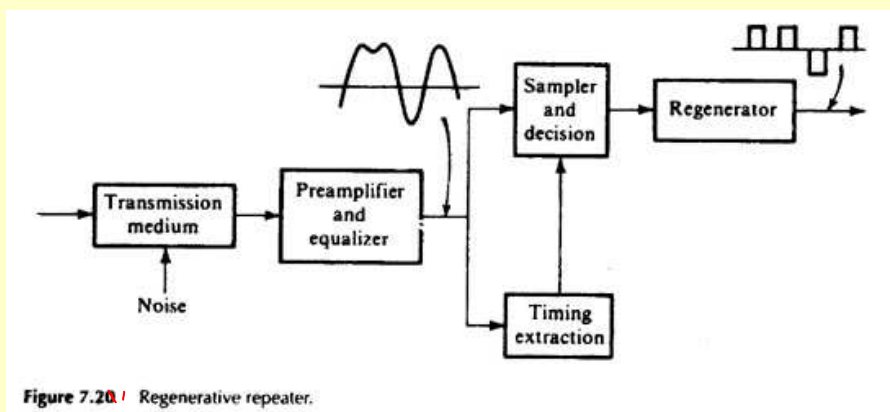

Dr. Shi

Lathi & Ding-Digital Commun

79

Preamplifier and Equalizer

- A pulse train is attenuated and distorted by transmission medium, say, dispersion caused by an attenuation of high-frequency components.
- Restoration of high frequency components \Rightarrow increase of channel noise
- Fortunately, digital signals are more robust.
 - Considerable pulse dispersion can be tolerated
- Main concern:
 - Pulse dispersion \Rightarrow ISI
 - \Rightarrow increase error probability in detection

Dr. Shi

Lathi & Ding-Digital Commun

80

Zero-Forcing Equalizer

- Detection decision is based solely on sample values.
 - ⇒ No need to eliminate ISI for all t . All that is needed is to eliminate or minimize ISI at their respective sampling instants only.
- This could be done by using the transversal-filter equalizer, which forces the equalizer output pulse to have zero values at the sampling (decision-making) instant. (refer to the diagram in next slide)

Dr. Shi

Lathi & Ding-Digital Commun

81

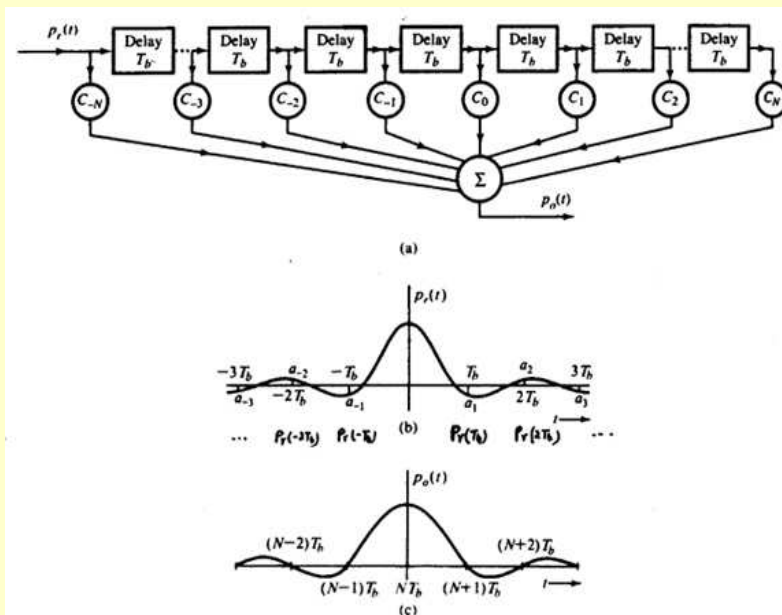

Figure 7.23 Zero-forcing equalizer analysis.

Zero-Forcing Equalizer ...

- Let $c_0 = 1$
 $c_k = 0 \quad \forall k \neq 0$ } *tap setting*

$$\Rightarrow P_0(t) = P_r(t - NT_b)$$

$$P_0(t) = P_r(t) \quad \text{If ignore delay.}$$

- Fig 7.22 (b) indicates a problem :
 $a_1, a_{-1}, a_2, a_{-2}, \dots$ are not negligible due to dispersion.
- Now, want to force $a_1 = a_{-1} = a_2 = a_{-2} = \dots = 0$
- Consider c_k 's assume other values (other tap setting).

Zero-Forcing Equalizer ...

- Consider c_k 's assume other values (other tap setting).

$$p_0(t) = \sum_{n=-N}^N c_n p_r(t - nT_b)$$

$$p_0(kT_b) = \sum_{n=-N}^N c_n p_r[(k-n)T_b], \quad k = 0, \pm 1, \pm 2, \dots$$

- For simplicity of notation:

$$p_0(k) = \sum_{n=-\infty}^{\infty} c_n p_r(k-n)$$

- Nyquist Criterion:

$$p_0(k) = 0 \quad \forall k \neq 0$$

$$p_0(k) = 1 \quad \text{for } k = 0$$

Zero-Forcing Equalizer ...

- \Rightarrow A set of infinitely many simultaneous equations:

$$2N+1: c_n \text{'s}$$

Impossible to solve this set of equations.

- If, however, we specify the values of $p_0(k)$ only at $2N+1$ points:

$$p_0(k) = \begin{cases} 1 & k = 0 \\ 0 & k = \pm 1, \pm 2, \dots, \pm N \end{cases}$$

then a unique solution exists.

Zero-Forcing Equalizer ...

- Meaning: Zero ISI at the sampling instants of N preceding and N succeeding pulses.
- Since pulse amplitude decays rapidly, ISI beyond the N^{th} pulse is not significant for $N > 2$ in general.

Zero-Forcing Equalizer ...

$$\begin{matrix} p_o(-N) \\ \vdots \\ p_o(-1) \\ p_o(0) \\ p_o(1) \\ \vdots \\ p_o(N) \end{matrix} \begin{bmatrix} 0 \\ 0 \\ \dots \\ 0 \\ 1 \\ 0 \\ \dots \\ 0 \\ 0 \end{bmatrix} = \begin{bmatrix} p_r[0] & p_r[-1] & \dots & p_r[-2N] \\ p_r[1] & p_r[0] & \dots & p_r[-2N+1] \\ \dots & \dots & \dots & \dots \\ p_r[N-1] & p_r[N-2] & \dots & p_r[-N-1] \\ p_r[N] & p_r[N-1] & \dots & p_r[-N] \\ p_r[N+1] & p_r[N] & \dots & p_r[-N+1] \\ \dots & \dots & \dots & \dots \\ p_r[2N-1] & p_r[2N-2] & \dots & p_r[1] \\ p_r[2N] & p_r[2N-1] & \dots & p_r[0] \end{bmatrix} \begin{bmatrix} c_{-N} \\ c_{-N+1} \\ \dots \\ c_{-1} \\ c_0 \\ c_1 \\ \dots \\ c_{N-1} \\ c_N \end{bmatrix} \quad (7.45)$$

The tap-gain c_k 's can be obtained by solving this set of equations.

Think about when $n = 2, 1, 0, -1, -2$; an example in next slide

Zero-Forcing Equalizer ...

EXAMPLE 7.3 For the received pulse $p_r(t)$ in Fig. 7.21b, let

$$a_0 = p_r[0] = 1$$

$$a_1 = p_r[1] = -0.3, \quad a_2 = p_r[2] = 0.1$$

$$a_{-1} = p_r[-1] = -0.2, \quad a_{-2} = p_r[-2] = 0.05$$

- Design a three-tap ($N = 1$) equalizer.

Substituting the preceding values into Eq. (7.45), we obtain

$$\begin{bmatrix} 0 \\ 1 \\ 0 \end{bmatrix} = \begin{bmatrix} 1 & -0.2 & 0.05 \\ -0.3 & 1 & -0.2 \\ 0.1 & -0.3 & 1 \end{bmatrix} \begin{bmatrix} c_{-1} \\ c_0 \\ c_1 \end{bmatrix}$$

Solution of this set yields $c_{-1} = 0.210$, $c_0 = 1.13$, and $c_1 = 0.318$. This tap setting assures us that $p_r[0] = 1$ and $p_r[-1] = p_r[1] = 0$. The output $p_o(t)$ is sketched in Fig. 7.21c.

Eye Diagram

- A convenient way to study ISI on an oscilloscope
- Figure

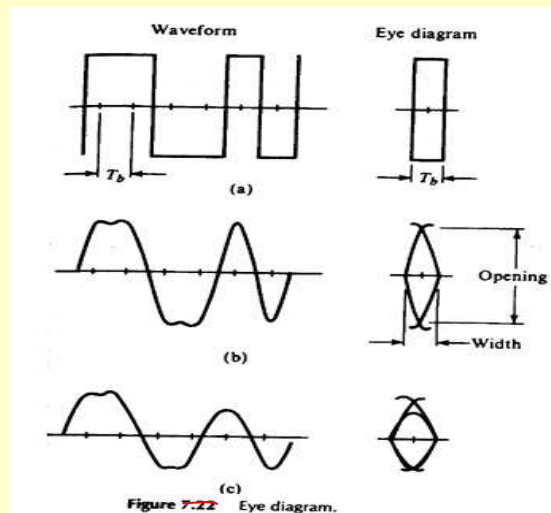

Dr. Shi

89

Timing Extraction

- The received signal needs to be sampled at precise instants.
- Timing is necessary.
- Three ways for synchronization:
 1. Derivation from a primary or a secondary standard (a master timing source exists, both transmitter and receiver follow the master).
 2. Transmitting a separate synchronizing signal (pilot clock)
 3. Self synchronization (timing information is extracted from the received signal itself).

Dr. Shi

Lathi & Ding-Digital Commun

90

Timing Extraction ...

- Way 1: Suitable for large volumes of data
high speed comm. Systems.
→ High cost.
- Way 2: Part of channel capacity is used to transmit
timing information.
→ Suitable for a large available capacity.
- Way 3: Very efficient.
- Examples:
 - On-off signaling (decomposition: Fig. 7.2)
 - Bipolar signaling rectification → on-off signaling

Timing Jitter

- Small random deviation of the incoming pulses
from their ideal locations.
- Always present, even in the most sophisticated
communication systems.
- Jitter reduction is necessary about every 200
miles in a long digital link to keep the maximum
jitter within reasonable limits.
- Figure 7.23

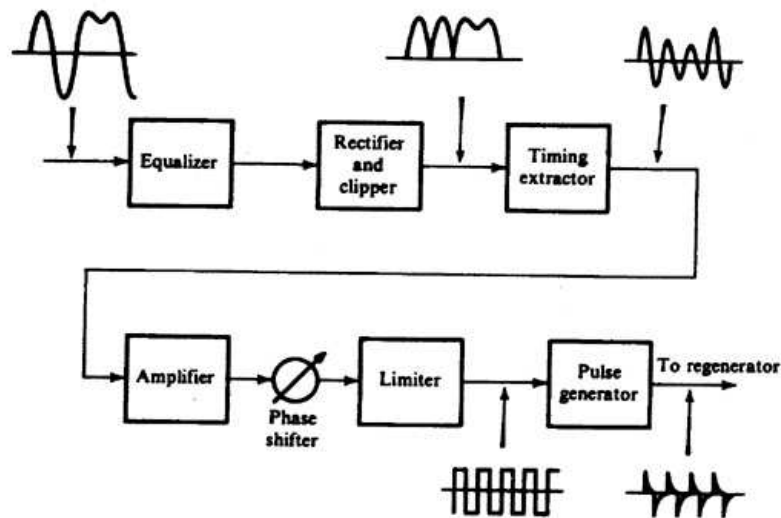

Figure 7.23 Timing extraction.

Dr. Shi

Lathi & Ding-Digital Commun

93

Detection –Error Probability

- Received signal = desired + AWGN
Example: Polar signaling and transmission (Fig. 7.24, the next slide)
 A_p : Peak signal value
- Polar: Instead of $\pm A_p$, received signal = $\pm A_p + n$
- Because of symmetry, the detection threshold = 0. ✓
 - If sample value ≥ 0 , \Rightarrow “1”
 - If sample value < 0 , \Rightarrow “0”
 - Error in detection may take place

Dr. Shi

Lathi & Ding-Digital Commun

94

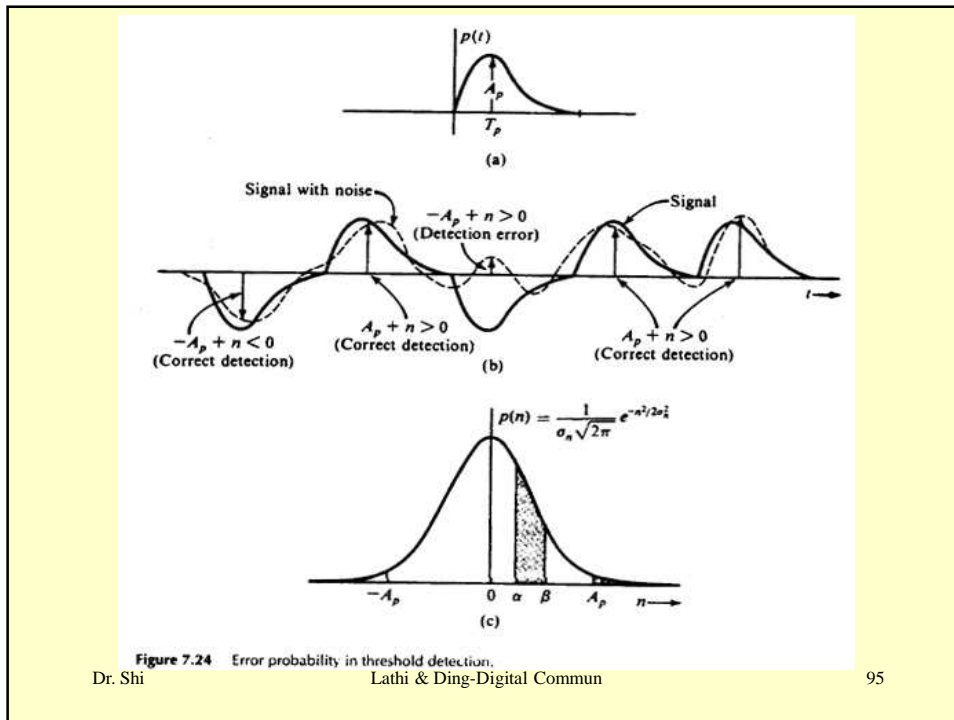

Error Probability for Polar Signal

- With respect to Figure 7.24

$$\left\{ \begin{array}{l} P(\epsilon / 0) = \text{probability that } n > A_p \\ P(\epsilon / 1) = \text{probability that } n < -A_p \end{array} \right.$$

$$n: \text{AWGN} \quad p(n) = \frac{1}{\sqrt{2\pi}\sigma_n} e^{-\frac{1}{2}\left(\frac{n}{\sigma_n}\right)^2}$$

$$\Rightarrow P(\epsilon / 0) = \frac{1}{\sigma_n \sqrt{2\pi}} \int_{A_p}^{\infty} e^{-\frac{1}{2}\left(\frac{n}{\sigma_n}\right)^2} dn$$

$$= \frac{1}{\sqrt{2\pi}} \int_{\frac{A_p}{\sigma_n}}^{\infty} e^{-\frac{1}{2}x^2} dx = Q\left(\frac{A_p}{\sigma_n}\right)$$

$$\boxed{x = \frac{n}{\sigma_n}}$$

Error Probability for Polar Signal...

where $Q(y) = \frac{1}{\sqrt{2\pi}} \int_y^{\infty} e^{-\frac{x^2}{2}} dx$

- Similarly,

$$P(\epsilon/1) = Q\left(\frac{A_p}{\sigma_n}\right) \quad \left(\begin{array}{l} -A_p \text{ to } -\infty \\ \text{Symmetric} \end{array} \right)$$

- Summary:

$$P(\epsilon) = P(\epsilon,0) + P(\epsilon,1) \quad \text{Here, assume } P(0) = P(1) = 1/2.$$

$$= P(\epsilon/0)P(0) + P(\epsilon/1)P(1)$$

$$= \frac{1}{2}[P(\epsilon/0) + P(\epsilon/1)] = Q\left(\frac{A_p}{\sigma_n}\right)$$

- $Q(x)$: Complementary error function: $erfc(x)$

$$Q(x) \cong \frac{1}{x\sqrt{2\pi}} \left(1 - \frac{0.7}{x^2}\right) e^{-\frac{x^2}{2}}, x > 2$$

Dr. Shi

Lathi & Ding-Digital Commun

97

Error Probability for Polar Signal...

- If $\frac{A_p}{\sigma_n} = k, P(\epsilon/0) = P(\epsilon/1) = P(\epsilon) = Q(k)$

k	1	2	3	4	5	6
$Q(k)=P(\epsilon)$	0.1587	0.0227	0.00135	3.16×10^{-5}	2.87×10^{-7}	9.9×10^{-9}

e.g. $3.16 \times 10^{-5} \Rightarrow$ one of 3.16×10^5 pulses will be possibly detected wrongly

Dr. Shi

Lathi & Ding-Digital Commun

98

Error Probability for On-off Signals

- In this case, we have to distinguish between A_p and 0.

- Threshold: $\frac{1}{2} A_p$ ✓

- Error Probabilities:

$$P(\epsilon/0) = \text{prob. of } n > \frac{1}{2} A_p = Q\left(\frac{A_p}{2\sigma_n}\right)$$

$$P(\epsilon/1) = \text{prob. of } n < \frac{1}{2} A_p = Q\left(\frac{A_p}{2\sigma_n}\right)$$

$$P(\epsilon) = \frac{1}{2} [P(\epsilon/0) + P(\epsilon/1)] = Q\left(\frac{A_p}{2\sigma_n}\right)$$

Also assume 0 and 1 equally probable

$P(\epsilon) > P(\epsilon)$ (in the case of polar signaling)

Dr. Shi

Lathi & Ding-Digital Commun

99

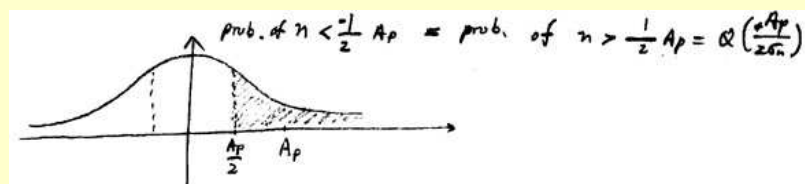

Dr. Shi

Lathi & Ding-Digital Commun

100

Error Probability for Bipolar Signals

$$1 \leftrightarrow A_p \text{ or } -A_p$$

$$0 \leftrightarrow 0v$$

$$\Rightarrow \text{ If the detected sample value: } \in \left(-\frac{A_p}{2}, \frac{A_p}{2} \right) \leftrightarrow 0$$

o.w. $\leftrightarrow 1$

$$\begin{aligned} P(\epsilon/0) &= \text{prob.} \left(|n| > \frac{A_p}{2} \right) \\ &= \text{prob.} \left(n > \frac{A_p}{2} \right) + \text{prob.} \left(n < -\frac{A_p}{2} \right) \\ &= 2 \text{prob.} \left(n > \frac{A_p}{2} \right) = 2Q \left(\frac{A_p}{2\sigma_n} \right) \end{aligned}$$

Dr. Shi

Lathi & Ding-Digital Commun

101

Error Prob. for Bipolar Signals...

$$P(\epsilon/1) = \text{prob.} \left(n < -\frac{A_p}{2} \right) \text{ when positive pulse used}$$

$$\text{or } \text{prob.} \left(n > \frac{A_p}{2} \right) \text{ when negative pulse used}$$

$$= Q \left(\frac{A_p}{2\sigma_n} \right)$$

$$P(\epsilon) = P(\epsilon/0)P(0) + P(\epsilon/1)P(1) = \frac{1}{2} [P(\epsilon/0) + P(\epsilon/1)]$$

$$= 1.5Q \left(\frac{A_p}{2\sigma_n} \right) > P(\epsilon) \text{ for on-off signaling}$$

Dr. Shi

Lathi & Ding-Digital Commun

102

Detection Error Probability...

- Summary, polar is the best, $Q\left(\frac{A_p}{\sigma_n}\right)$
 - on-off is in middle, $Q\left(\frac{A_p}{2\sigma_n}\right)$
 - bipolar is the worst, $1.5Q\left(\frac{A_p}{2\sigma_n}\right)$
- Assumption:
"0" and "1"
Equally likely
- Another factor:
 $P(\epsilon)$ decreases exponentially with the signal power.

Comparison among three line codes

- To obtain: $P(\epsilon) = 0.286 \times 10^{-6}$
- We need: $\frac{A_p}{\sigma_n} = 5$ for polar case $\because Q(5) = 0.286 \times 10^{-6}$
- $\frac{A_p}{\sigma_n} = 10$ for on-off case $\because P(\epsilon) = Q\left(\frac{A_p}{2\sigma_n}\right)$
- $\frac{A_p}{\sigma_n} = 10.16$ for bipolar case $\because P(\epsilon) = 1.5Q\left(\frac{A_p}{2\sigma_n}\right)$
- $= 0.286 \times 10^{-6}$
- $\Downarrow \frac{A_p}{2\sigma_n} = 5.08$

Comparison among three line codes...

- For the same error rate, required $\text{SNR}\left(\frac{A_p}{\sigma_n}\right)$,
Polar < On-off < Bipolar (from previous example)
- For the same $\text{SNR}\left(\frac{A_p}{\sigma_n}\right)$, the caused error rate
Polar < On-off < Bipolar (from next example)
- Polar is most efficient in terms of SNR vs. error rate
- Between, on-off and bipolar:
Only 16% improvement of on-off over bipolar
- Performance of bipolar case \approx performance of on-off case in terms of error rate.

Example

- a) Polar binary pulses are received with peak amplitude $A_p = 1$ mV. The channel noise rms amplitude is 192.3 μ V. Threshold detection is used, and 1 and 0 are equally likely.
- b) Find the error probability for
 - (i) the polar case, and the on-off case
 - (ii) the bipolar case if pulses of the same shape as in part (a) are used, but their amplitudes are adjusted so that the transmitted power is the same as in part (a)

Example ...

a) For the polar case $\frac{A_p}{\sigma_n} = \frac{10^{-3}}{192.3(10^{-6})} = 5.2$

From Table 8.2 (4th ed), we find

$$P(\epsilon) = Q(5.2) = 0.9964 \times 10^{-7}$$

b) Because half the bits are transmitted by no-pulse, there are, on the average, only half as many pulses in the on-off case (compared to the polar). Now, doubling the pulse energy is accomplished by multiplying the pulse by $\sqrt{2}$

(in order to keep the power dissipation same)

Example...

Thus, for on-off A_p is $\sqrt{2}$ times the A_p in the polar case.

•Therefore, from Equation (7.53)

$$P(\epsilon) = Q\left(\frac{A_p}{2\sigma_n}\right) = Q(3.68) = 1.66 \times 10^{-4}$$

•As seen earlier, for a given power, the A_p for both the on-off and the bipolar cases are identical.

Hence, from equation (7.54)

$$P(\epsilon) = 1.5Q\left(\frac{A_p}{2\sigma_n}\right) = 1.749 \times 10^{-4}$$

M-ary Communication

- Digital communications use only a finite number of symbols
- Information transmitted by each symbol increases with M .

$$I_M = \log_2 M \text{ bits} \quad I_M : \text{information transmitted by an } M\text{-ary symbol}$$

- Transmitted power increases as M^2 , i.e., to increase the rate of communication by a factor of $\log_2 M$, the power required increases as M^2 .

(see an example below)

M-ary Communication...

- Most of the terrestrial digital telephone network: Binary
- The subscriber loop portion of the integrated services digital network (ISDN) uses the quaternary code 2BIQ shown in Figure. 7.28

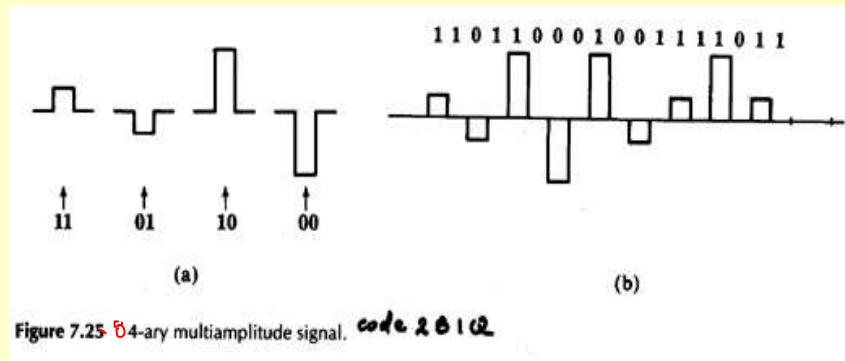

Figure 7.25 84-ary multi-amplitude signal. *code 110110001001111011*

Pulse Shaping in Multi-amplitude Case

- Nyquist Criterion } can be used for M-ary case
- Controlled ISI }
- Figure 7.28: One possible M-ary Scheme
- Another Scheme: Use M orthogonal pulses:

$$\varphi_1(t), \varphi_2(t), \dots, \varphi_M(t)$$

- Definition:

$$\int_0^{T_b} \varphi_i(t) \varphi_j(t) dt = \begin{cases} c & i = j \\ 0 & i \neq j \end{cases}$$

Pulse Shaping in Multi-amplitude Case

- The figure in next slide: One example in M orthogonal pulses:

$$\varphi_k(t) = \begin{cases} \sin \frac{2\pi \cdot k \cdot t}{T_b}, & 0 < t < T_b \quad k = 1, 2, \dots, M \\ 0, & \text{otherwise} \end{cases}$$

- In the set, pulse frequency:

$$k \frac{1}{T_b} : \frac{1}{T_b}, \frac{2}{T_b}, \dots, \frac{M}{T_b} \quad \leftarrow \begin{array}{l} \text{M times that of the binary} \\ \text{scheme} \end{array} \quad (\text{see an example below})$$

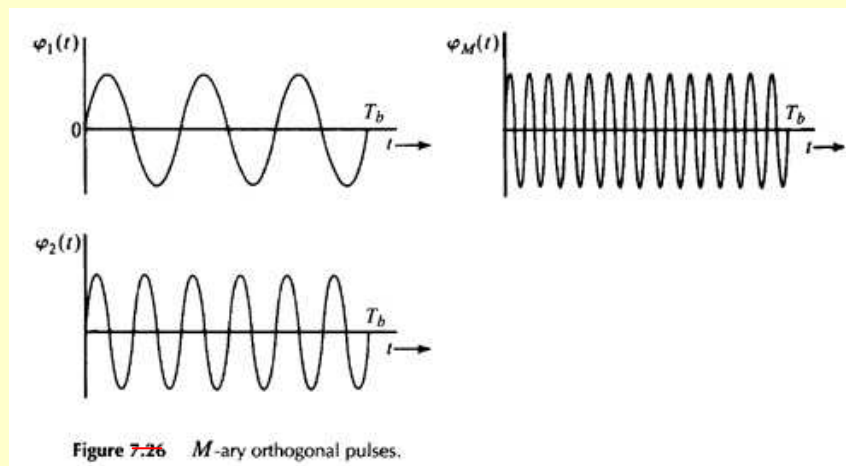

Pulse Shaping in Multi-amplitude Case

- In general, it can be shown that the bandwidth of an orthogonal M-ary scheme is M times that of the binary scheme
 - In an M-ary orthogonal scheme, the rate of communication is increased by a factor of $\log_2 M$ at the cost of an increase in transmission bandwidth by a factor of M.

Digital Carrier Systems

- So far: Baseband digital systems
 - Signals are transmitted directly without any shift in frequency.
 - Suitable for transmission over wires, cables, optical fibers.
- Baseband signals cannot be transmitted over a radio link or satellites.
 - Since it needs impractically large size for antennas
 - Modulation (Shifting signal spectrum to higher frequencies is needed)

Digital Carrier Systems...

- A spectrum shift to higher frequencies is also required when transmitting several messages simultaneously by sharing the large bandwidth of the transmission medium,
- FDM: Frequency-division Multiplexing.
(FDMA: Frequency-division Multiplexing Access)

Dr. Shi

Lathi & Ding-Digital Commun

117

Several Types of Modulation

- Amplitude-Shift Keying (ASK), also known as on-off keying (OOK)

$m(t) \cos(\omega_c t)$: $m(t)$: on-off baseband signal (modulating signal)
 $\cos(\omega_c t)$: carrier

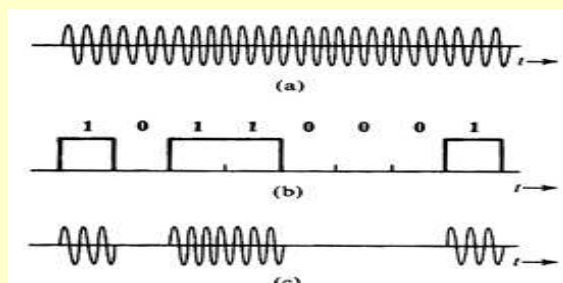

Figure 7.27 (a) Carrier $\cos \omega_c t$. (b) Modulating signal $m(t)$. (c) ASK: modulated signal $m(t) \cos \omega_c t$.

Dr. Shi

118

Modulation Types...

- Phase-Shift Keying (PSK)

$m(t)$: polar Signal

$$1 \leftrightarrow p(t)\cos(\omega_c t), 0 \leftrightarrow -p(t)\cos(\omega_c t) = p(t)\cos(\pi - \omega_c t) = p(t)\cos(\omega_c t - \pi)$$

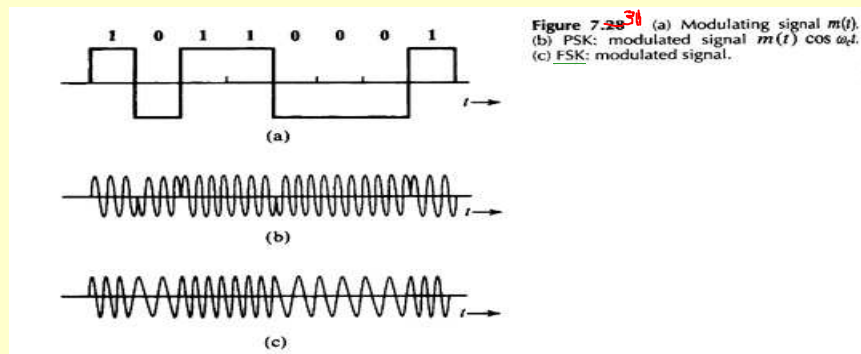

Dr. Shi

Lathi & Ding-Digital Commun

119

Modulation Types...

- Frequency-Shift Keying (FSK)

– Frequency is modulation by the base band signal.

$$1 \leftrightarrow \omega_{c_1}, 0 \leftrightarrow \omega_{c_0}$$

– Information bit resides in the carrier frequency.

Dr. Shi

Lathi & Ding-Digital Commun

120

PSD of ASK, PSK & FSK

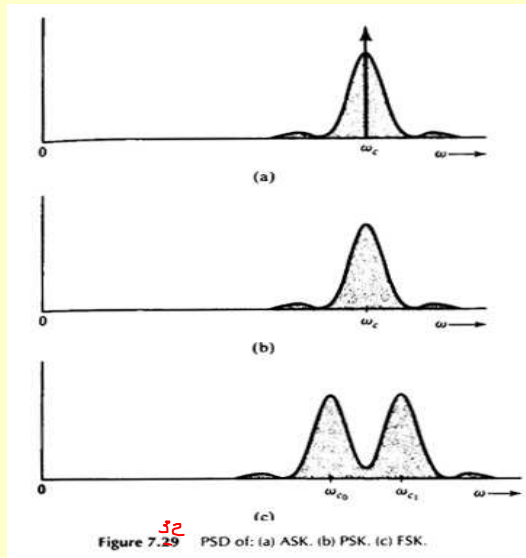

Dr. Shi

121

FSK

- FSK signal may be viewed as a sum of two interleaved ASK signals, one with a modulating frequency ω_{c_0} , the other, ω_{c_1}
 - Spectrum of FSK = Sum of the two ASK
 - Bandwidth of FSK is higher than that of ASK or PSK

Dr. Shi

Lathi & Ding-Digital Commun

122

Demodulation

A. Review of Analog Demodulation

- Baseband signal and bandpass signal
The end of the 2nd part of the slides of Ch. 2 and Ch. 3
- Double-sideband Suppressed Carrier (DSB-SC) Modulation

$$m(t) \leftrightarrow M(\omega) \quad \text{message signal}$$

$$\cos(\omega_c t) \leftrightarrow \frac{1}{2} [\delta(\omega + \omega_c) + \delta(\omega - \omega_c)] \quad \text{carrier}$$

$$m(t) \cos(\omega_c t) \leftrightarrow \frac{1}{2} [M(\omega + \omega_c) + M(\omega - \omega_c)] \quad \text{modulated signal}$$

Dr. Shi

Lathi & Ding-Digital Commun

123

Figure 4.1 (a), (b), (c) DSB-SC Modulation

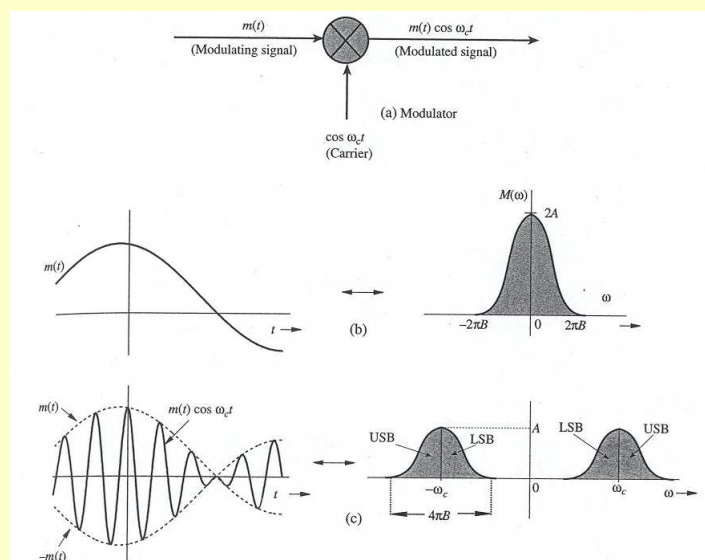

124

DSB-SC Demodulation

- Demodulation:
Synchronization Detection
(Coherent Detection) } Using a carrier of
exactly the same
frequency & pulse
- Figure 4.1 (e) and (d)

DSB-SC Demodulation ...

$$[m(t) \cos(\omega_c t)] \cos(\omega_c t) = e(t) = \frac{1}{2} [m(t) + m(t) \cos(2\omega_c t)]$$

$$E(\omega) = \frac{1}{2} M(\omega) + \frac{1}{4} [M(\omega + 2\omega_c) + M(\omega - 2\omega_c)]$$

$$\text{After } LPF \Rightarrow \frac{1}{2} M(\omega)$$
$$\frac{1}{2} m(t)$$

Figure 4.1 (d), (e) DSB-SC demodulation

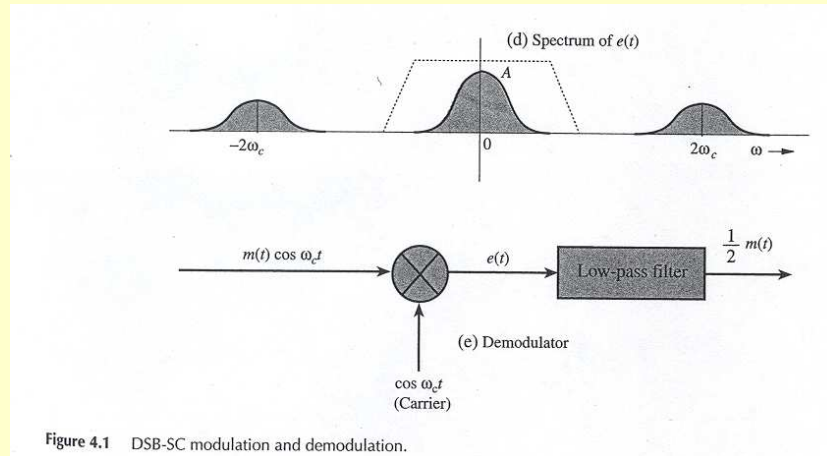

Figure 4.1 DSB-SC modulation and demodulation.

127

AM Signal

- Motivation:
 - Requirements of a carrier in frequency and phase synchronism with carrier at the transmitter is too sophisticated and quite costly
 - Sending the carrier \Rightarrow a. eases the situation
b. requires more power in transmission
c. suitable for broadcasting

Dr. Shi

128

Amplitude Modulation (AM)

$$\begin{aligned}\varphi_{AM}(t) &= A \cos(\omega_c t) + m(t) \cos(\omega_c t) \\ &= [A + m(t)] \cos(\omega_c t)\end{aligned}$$

$$\begin{aligned}\varphi_{AM}(t) &\Leftrightarrow \frac{1}{2} [M(\omega + \omega_c) + M(\omega - \omega_c)] \\ &\quad + \pi \cdot A [\delta(\omega + \omega_c) + \delta(\omega - \omega_c)]\end{aligned}$$

Dr. Shi

129

- AM Signal and its Envelope

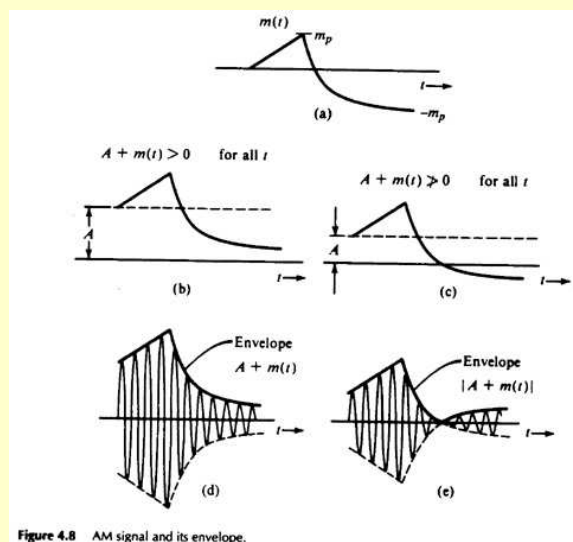

130

- Demodulation of AM signals

- Rectifier Detection: Figure 4.11

Output: $\frac{1}{\pi}m(t)$

- Envelope Detector: Figure 4.12

Output: $A + m(t)$

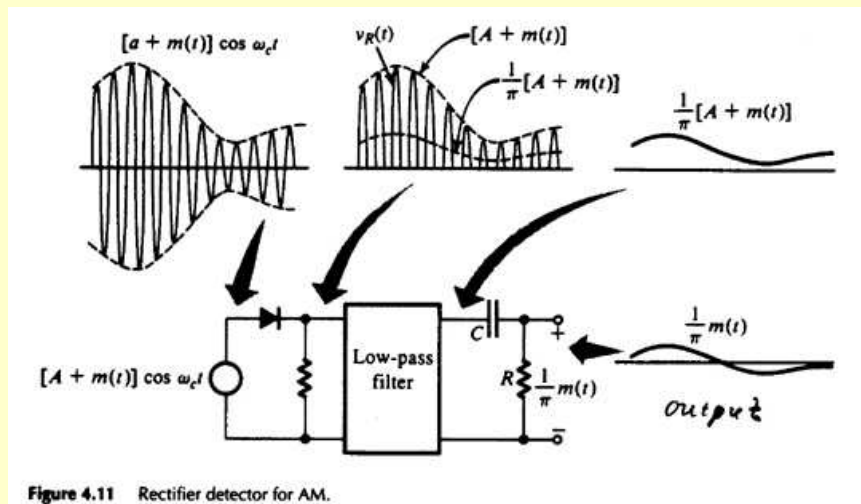
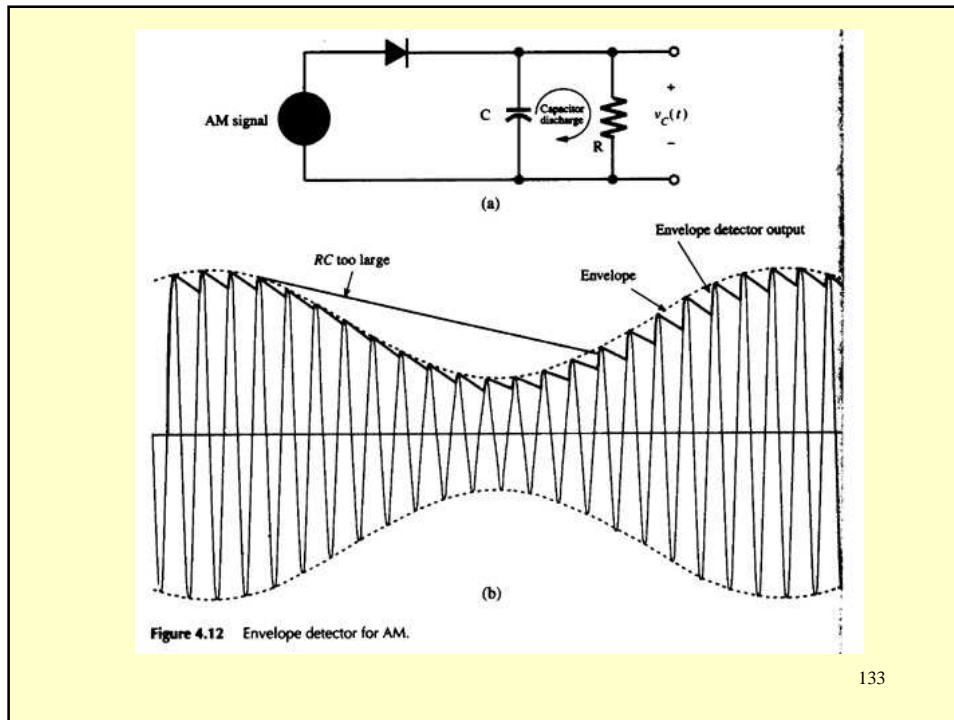

Figure 4.11 Rectifier detector for AM.



133

B. Back to Digital Communication System: Demodulation

- Demodulation of Digital-Modulated Signals is similar to Demodulation of Analog-Modulated Signals
- Demodulation of ASK
 - ✓ Synchronous (Coherent) Detection
 - ✓ Non-coherent Detection: Say, envelope detection

Demodulation of PSK

- Cannot be demodulated non-coherently (envelope detection).
 - Since, envelope is the same for 0 and 1
- Can be demodulated coherently.
- PSK may be demodulated non-coherently if use: Differential coherent PSK (DPSK)

Differential Encoding

- Differential coding:
 - “1” \leftrightarrow encoded by the same pulse used to encode the previous data bit \rightarrow no transition
 - “0” \leftrightarrow encoded by the negative of pulse used to encode the previous data bit \rightarrow transition
- Figure 7.30 (a)
- Modulated signal consists of pulses $\pm A \cos(\omega_c t)$ with a possible sign ambiguity

Differential Encoding

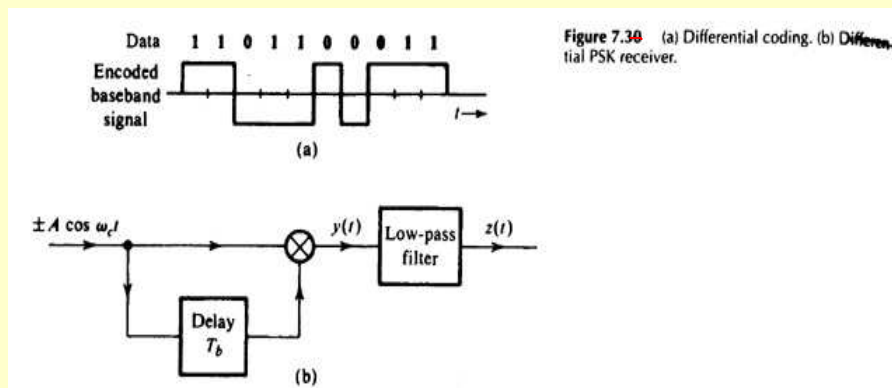

Dr. Shi

Lathi & Ding-Digital Commun

137

Differential Encoding...

- T_b : one-bit interval
- If the received pulse is identical to the previous pulse $\leftarrow \rightarrow 1$,

$$Y(t) = A^2 \cos^2(\omega_c t) = \frac{A^2}{2} [1 + \cos(2\omega_c t)]$$

$$z(t) = \frac{A^2}{2}$$

- If 0 is transmitted

$$Y(t) = -A^2 \cos^2(\omega_c t) = -\frac{A^2}{2} [1 + \cos(2\omega_c t)]$$

$$z(t) = -\frac{A^2}{2}$$

Dr. Shi

Lathi & Ding-Digital Commun

138

Demodulation of FSK

- FSK can be viewed as two interleaved ASK signals with carrier frequency ω_{c_0} and ω_{c_1} , respectively.
- Hence, FSK can be detected by non-coherent detection (envelope) or coherent detection technique

Dr. Shi

Lathi & Ding-Digital Commun

139

Demodulation of FSK

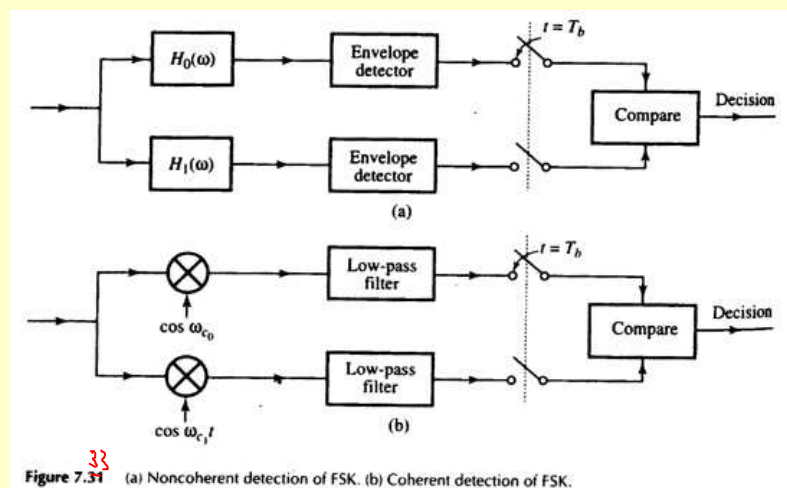

Dr. Shi

Lathi & Ding-Digital Commun

140

Demodulation of FSK

- In (a), non-coherent detection (envelope),
 - $H_0(\omega)$ ω_{c_0}
Turned to ω_{c_1} respectively
 - $H_1(\omega)$ ω_{c_1}
- Comparison: above or bottom
Whose output is large \rightarrow 0 or 1